

Types D, E, F, FM, 2F, F9, interface connectors I/U

Page

Technical characteristics types D and E **02.10**

Type D connectors **02.11**

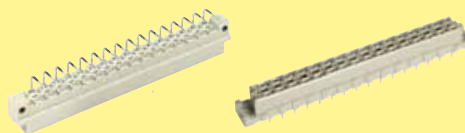

Type E connectors **02.15**



Technical characteristics piggyback connectors **02.20**

Piggyback connectors **02.21**



Technical characteristics types F, F9, FM and 2F **02.24**

Type F connectors **02.25**

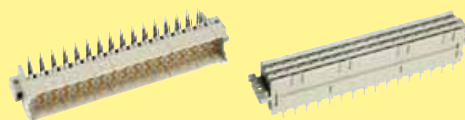

Type F9 connectors **02.35**



Type FM connectors **02.36**

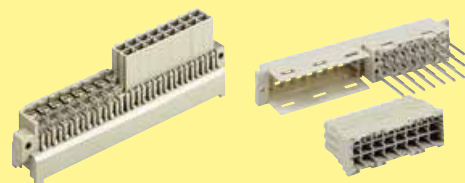

Type 2F connectors **02.38**

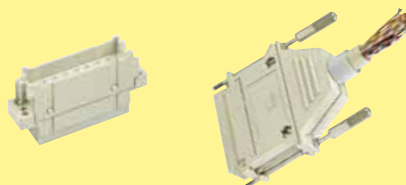

Coding systems **02.41**

Number of contacts	
Type D	32
Type E	48
Contact spacing (mm)	
Type D	5,08
Type E	male connector 5.08 x 5.08 male connector 2.54 x 5.08 female connector 5.08 x 5.08
Working current	6 A max. see current carrying capacity chart
Clearance	
Types D und E	≥ 3.0 mm
Type E male connector row separation 2.54 mm	≥ 1.6 mm
Creepage	≥ 3.0 mm
Working voltage	
The working voltage also depends on the clearance and creepage dimensions of the pcb itself and the associated wiring	according to the safety regulations of the equipment Explanations see chapter 00
Test voltage $U_{r.m.s.}$	1.55 kV
Contact resistance	≤ 15 mΩ for wire wrap and solder connections ≤ 20 mΩ including crimp connections
Insulation resistance	≥ 10 ¹² Ω
Temperature range	- 55 °C ... + 125 °C
The higher temperature limit includes the local ambient and heating effects of the contacts under load	
Degree of protection for crimp terminal	IP 20 according to DIN 40 050
Electrical termination	
Male connector	Solder pins for pcb connections Ø 1.0 ± 0.1 mm according to IEC 60 326-3 Wrap posts 1 x 1 mm diagonal 1.34-1.45 mm
Female connector	Solder pins for pcb connections Ø 1.0 ± 0.1 mm according to IEC 60 326-3 Angled solder pins 1 x 1 mm for pcb connections Ø 1.6 ± 0.1 mm Solder lugs Crimp terminal 0.09-1.5 mm ²
Insertion and withdrawal force	32 way ≤ 40 N 48 way ≤ 75 N
Materials	
Mouldings	Thermoplastic resin, glass-fibre filled, UL 94-V0
Contacts	Copper alloy
Contact surface	
Contact zone	Selectively gold plated according to performance level ¹⁾

¹⁾ Explanation of performance levels see chapter 00

Mating conditions see chapter 00
Coding systems see pages 02.41 and 02.42
Mounting clips see chapter 00

Current carrying capacity

The current carrying capacity is limited by maximum temperature of materials for inserts and contacts including terminals. The current capacity curve is valid for continuous, non interrupted current loaded contacts of connectors when simultaneous power on all contacts is given, without exceeding the maximum temperature.

Control and test procedures according to DIN IEC 60 512

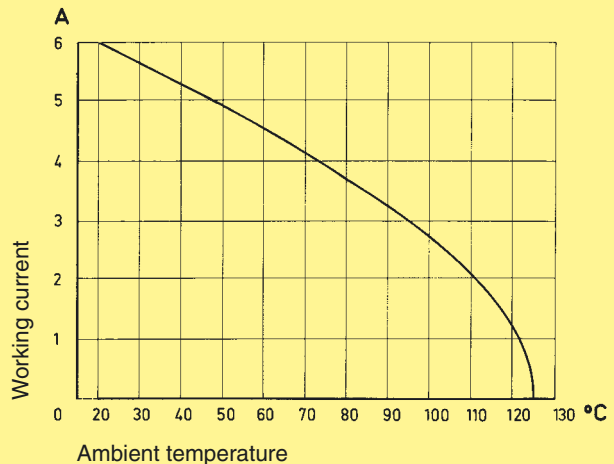

Fitting the crimp contacts

After crimping the wires onto the contacts with the help of a crimping tool or an automatic crimping machine the contacts should be correctly oriented and inserted into the cavities of the connector moulding in the required configuration. They snap into position and are firmly held in place. A light pull on the wire assures the correct tensile strength of the contact. When using stranded wires with a gauge below 0.37 mm² an insertion tool is necessary.

Removing the crimp contacts

The removal tool is inserted into a slot on the side of the respective crimp cavity. This action compresses the contact retaining spring therefore the contact can then be easily withdrawn using a light pull on the wire. This action will cause no damage to the contact/wire which can be repositioned/refitted as necessary. The drawing demonstrates the crimp removal procedure (max. 5x).

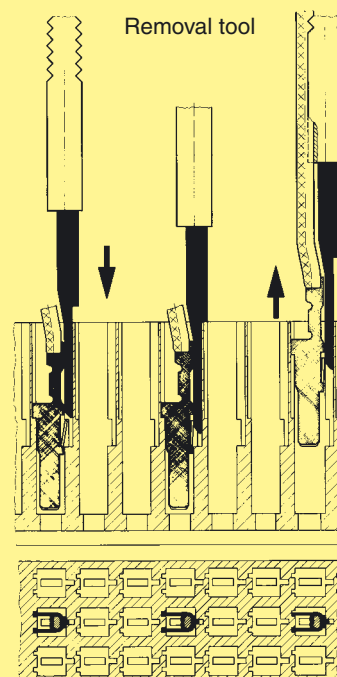

Number of contacts

32

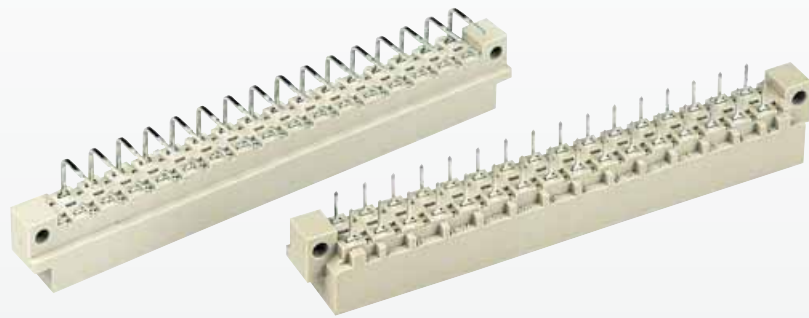

Male connectors

Identification	Number of contacts	Contact arrangement	Part No.	Performance levels according to IEC 60 603-2. Explanation chapter 00		
				3	2	1
Male connector with angled solder pins	32		09 04 132 7921	09 04 132 6921 09 04 332 6921 ^{b)} 09 04 632 6921 ^{c)}	09 04 132 2921	
	30 + 2 [▲]		09 04 132 7951	09 04 132 6951 09 04 632 6951 ^{c)}		
Male connector with straight solder pins	32		09 04 132 7922	09 04 132 6922		
	30 + 2 [▲]		09 04 132 7952	09 04 132 6952		

DIN Power to 6 A

Dimensions

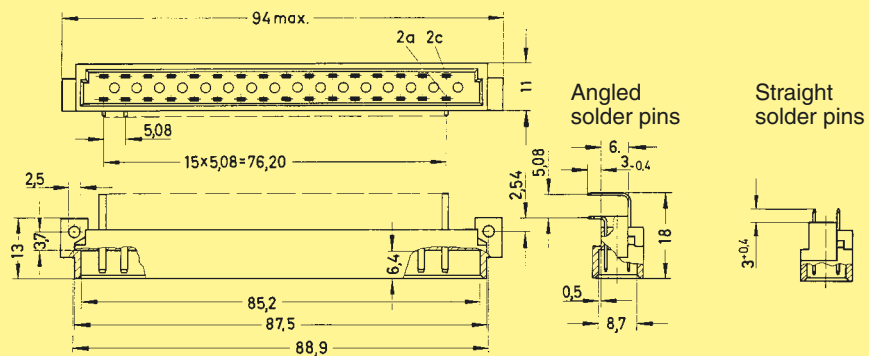

Board drillings

Mounting side

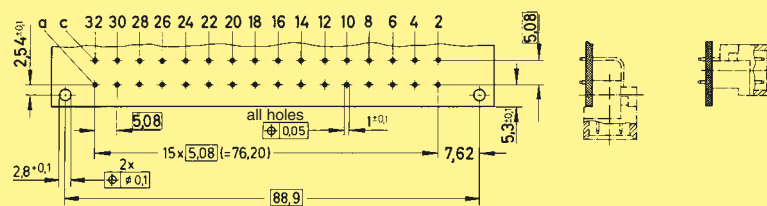

Dimensions in mm

▲ Male connectors with 2 leading contacts [(0.8 mm) pos. a2 and a32]
 Other contact arrangements on request
^{b)} Connectors with snap-in clips see chapter 00
^{c)} Connectors with coding see page 02.42

Number of contacts

32

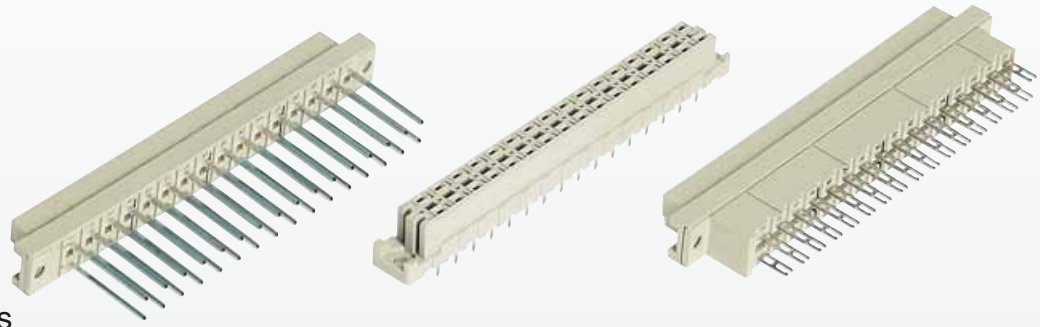

Female connectors

Identification	Number of contacts	Contact arrangement	Part No.	Performance levels according to IEC 60 603-2. Explanation chapter 00	3	2	1
Female connector with solder pins 2.9 mm	32		09 04 232 7832		09 04 232 6832		09 04 232 2832
Female connector with solder pins 4.5 mm	32		09 04 232 7831		09 04 232 6831 09 04 332 6831 ^{b)} 09 04 732 6831 ^{c)}		09 04 232 2831
Female connector with wrap posts 20 mm	32		09 04 232 7821		09 04 232 6821		09 04 232 2821
Female connector with solder lugs	32		09 04 232 7823		09 04 232 6823		09 04 232 2823

Dimensions

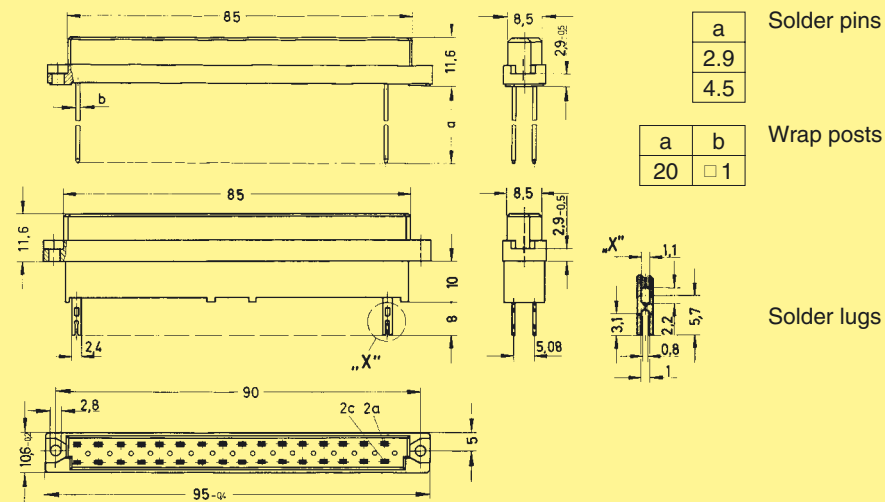

Panel cut out

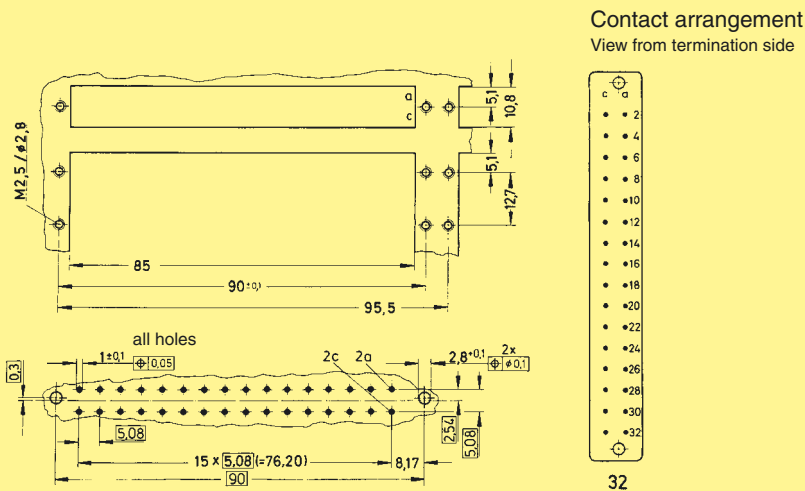

Board drillings
Mounting side

Dimensions in mm

^{b)} Connectors with snap-in clips see chapter 00
^{c)} Connectors with coding see page 02.42

Number of contacts

32



Female connectors

Identification Number of contacts Contact arrangement Part No. Performance levels according to IEC 60 603-2. Explanation chapter 00

Identification	Number of contacts	Contact arrangement	Part No.	3	2	1
Female connector with angled solder pins 1 x 1 mm	32		09 04 232 7826		09 04 232 6826	09 04 232 2826

Dimensions						
------------	--	--	--	--	--	--

Fixing bracket Metal			09 06 000 9912 ¹⁾			
----------------------	--	--	------------------------------	--	--	--

¹⁾ order 2 pieces for one connector

Board drillings Mounting side						
-------------------------------	--	--	--	--	--	--

Dimensions in mm

DIN Power 10 6 A

Number of contacts

max. 32

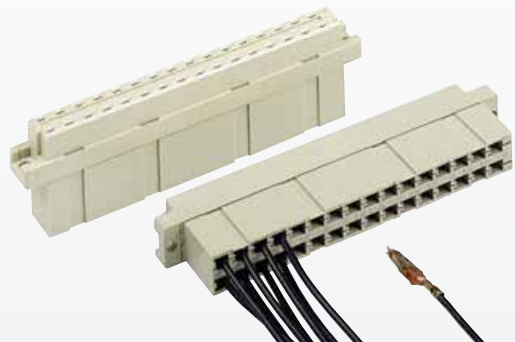

Female connectors

DIN Power 10 6 A

Identification	Number of contacts	Part No.	Drawing	Dimensions in mm
Female connector for crimp contacts Order contacts separately	32	09 04 032 3213		

Shell housing 09 03 096 0501 see chapter 20

Identification	Identification Wire gauge	Part No.	Performance levels according to IEC 60 603-2. Explanation chapter 00	
			2	1
Female crimp FC contacts				
Bandoliered contacts (approx. 2,500 pieces)	1	09 06 000 6484		09 06 000 6474
	2	09 06 000 6481		09 06 000 6471
	3	09 06 000 6482		09 06 000 6472
Bandoliered contacts (approx. 250 pieces)	1	09 06 000 7484		09 06 000 7474
	2	09 06 000 7481		09 06 000 7471
	3	09 06 000 7482		09 06 000 7472
Individual contacts ¹⁾	1	09 06 000 8484		09 06 000 8474
	2	09 06 000 8481		09 06 000 8471
	3	09 06 000 8482		09 06 000 8472

		Wire gauge mm ²	AWG	Insulation ø mm	Identification
FC 1	1	0.09 - 0.25	28 - 24	0.7 - 1.5	
FC 2	2	0.14 - 0.56	26 - 20	0.8 - 2.0	
FC 3	3	0.5 - 1.5	20 - 16	1.6 - 2.8	

3.5 + 0.5 mm of insulation is stripped from the wires to be crimped
Insertion, removal and crimping tools see chapter 30

¹⁾ Packaging unit 1,000 pieces

Number of contacts

48

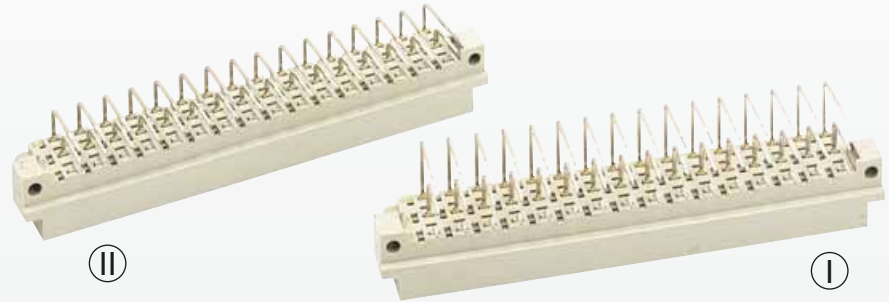

Male connectors

Identification	Number of contacts	Contact arrangement	Part No.	Performance levels according to IEC 60 603-2. Explanation chapter 00		
				3	2	1
Male connector with angled solder pins Row separation termination side 5.08 mm (I)	48		09 05 148 7921	09 05 148 6921 09 05 348 6921 ^{b)} 09 05 648 6921 ^{c)}	09 05 148 2921 09 05 648 2921 ^{c)}	
	46 + 2 [▲]		09 05 148 7951	09 05 148 6951		
	48		09 05 148 7931	09 05 148 6931	09 05 148 2931	
	46 + 2 [▲]		09 05 148 7961	09 05 148 6961		

Dimensions

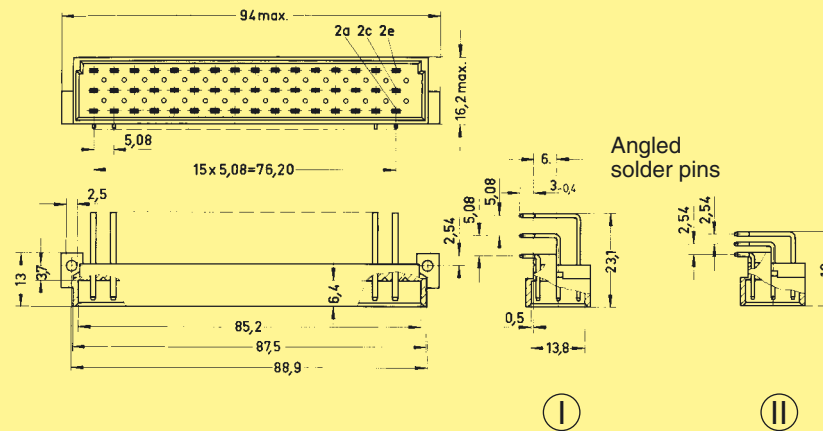

Board drillings

Mounting side

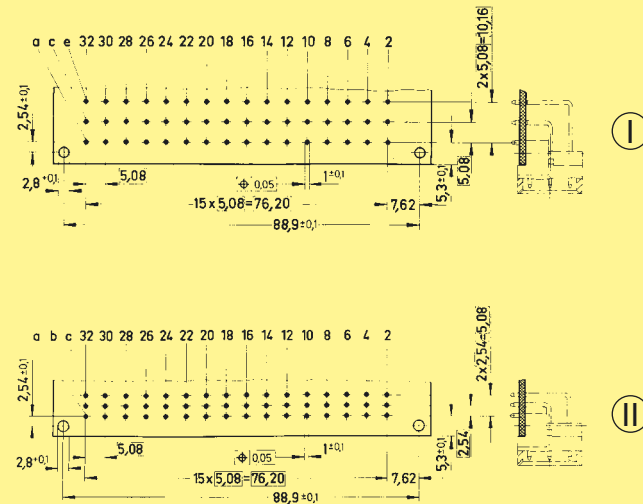

Dimensions in mm

▲ Male connectors with 2 leading contacts [(0.8 mm) pos. a2 and a32]

Other contact arrangements on request

^{b)} Connectors with snap-in clips see chapter 00

^{c)} Connectors with coding see page 02.42

Number of contacts

48

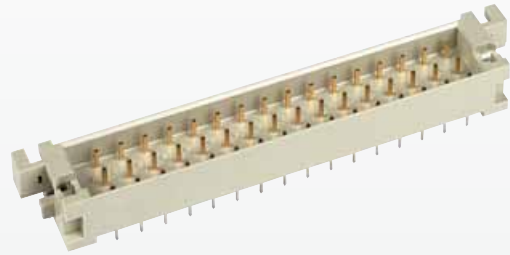

Interface connector I

DIN Power
10 6 A

Identification	Number of contacts	Part No.	Drawing	Dimensions in mm
Interface connector I with solder pins 0.6 x 0.6 mm	48	Performance level 2 acc. to IEC 60 603-2 09 05 048 6924	<p>Technical drawing showing contact arrangement and view from termination side. The drawing includes dimensions for the contact pitch (2.7 mm), overall length (95 mm), and contact positions (2a, 2c, 2e). It also shows a detailed view of the contact arrangement with positions 2, 4, 6, 8, 10, 12, 14, 16, 18, 20, 22, 24, 26, 28, 30, 32.</p>	<p>Technical drawing showing dimensions in mm. Key dimensions include: 95 (total length), 13.8 (height), 16.2 (height), 90 ± 0.1 (length), 97.5 (length), 6.4 (height), 85.2 (length), 88 (length), 106 (length), 5.25 (height), 4 (height), 12.2 (height), 5.25 (height), 17.5 (width).</p>
Panel cut out			<p>Technical drawing showing panel cut out dimensions. Key dimensions include: 10.2 (width), 85.2 (width), 90 ± 0.1 (width), 106.5 (width), 5.35 (height), 16.4 (height), 5.35 (height), 17.78 (width).</p>	<p>Technical drawing showing board drilling dimensions. Key dimensions include: 0.3 (drill diameter), 5.08 (drill diameter), 15 x 5.08 = 76.20 (drill diameter), 90 ± 0.1 (width), 8.17 (width), 2.54 (width), 5.08 (width), 2 x 5.08 = 10.16 (width), 6.2 (width). Reference: M 2.5 DIN EN ISO 4032.</p>
Board drillings Mounting side			<p>Technical drawing showing board drillings on the mounting side. Key dimensions include: 0.3 (drill diameter), 5.08 (drill diameter), 15 x 5.08 = 76.20 (drill diameter), 90 ± 0.1 (width), 8.17 (width), 2.54 (width), 5.08 (width), 2 x 5.08 = 10.16 (width), 6.2 (width). Reference: M 2.5 DIN EN ISO 4032.</p>	<p>Technical drawing showing board drillings on the mounting side. Key dimensions include: 0.3 (drill diameter), 5.08 (drill diameter), 15 x 5.08 = 76.20 (drill diameter), 90 ± 0.1 (width), 8.17 (width), 2.54 (width), 5.08 (width), 2 x 5.08 = 10.16 (width), 6.2 (width). Reference: M 2.5 DIN EN ISO 4032.</p>

Number of contacts

48

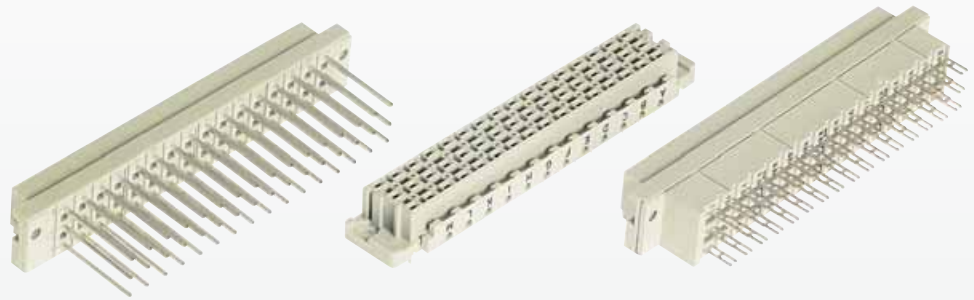

Female connectors

Identification	Number of contacts	Contact arrangement	Part No.	Performance levels according to IEC 60 603-2. Explanation chapter 00	
				3	2 1
Female connector with solder pins 2.9 mm	48		09 05 248 7832	09 05 248 6832	09 05 248 2832
Female connector with solder pins 4.5 mm	48		09 05 248 7831	09 05 248 6831 09 05 348 6831 ^{b)} 09 05 748 6831 ^{c)}	09 05 248 2831 09 05 748 2831 ^{c)}
Female connector with wrap posts 20 mm	48		09 05 248 7821	09 05 248 6821	09 05 248 2821
Female connector with solder lugs	48		09 05 248 7823	09 05 248 6823	09 05 248 2823

DIN Power 10 6 A

Female connector with press-in pins

Part Nos. and variants see chapter 04

Dimensions

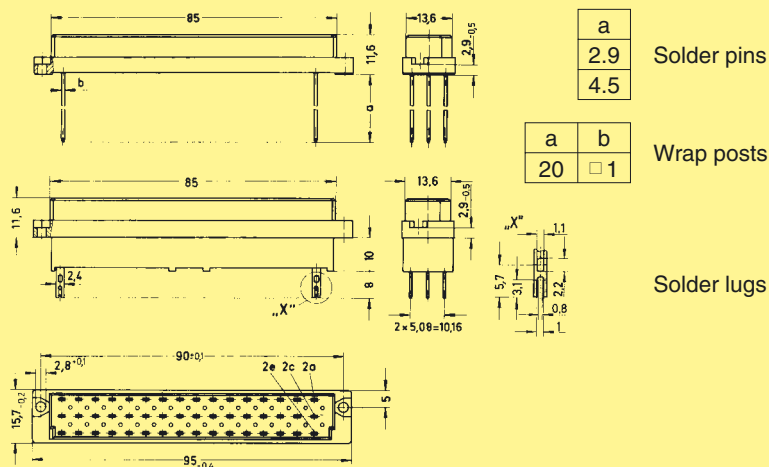

Panel cut out

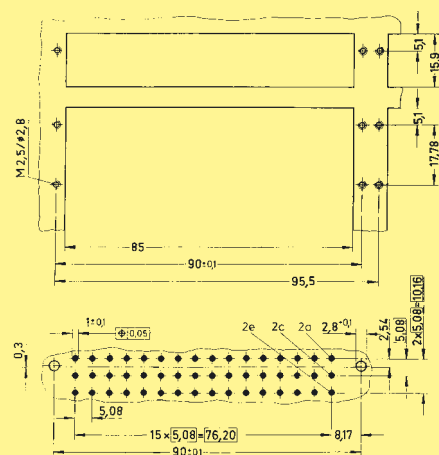

Contact arrangement

View from termination side



Board drillings

Mounting side

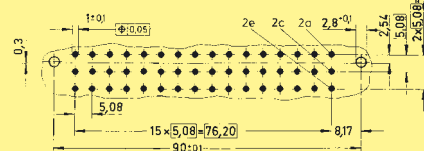

Dimensions in mm

^{b)} Connectors with snap-in clips see chapter 00
^{c)} Connectors with coding see page 02.42

Number of contacts

max. 48

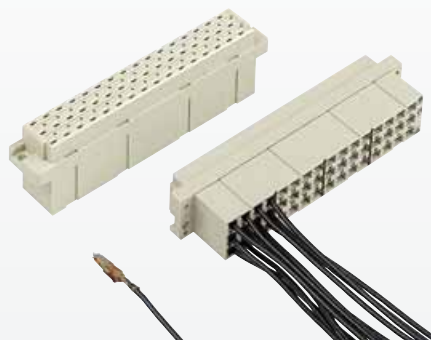

Female connectors

DIN Power
10 6 A

Identification	Number of contacts	Part No.	Drawing	Dimensions in mm
----------------	--------------------	----------	---------	------------------

Female connector for crimp contacts
Order contacts separately

48

09 05 048 3202
09 05 548 3202^{c)}

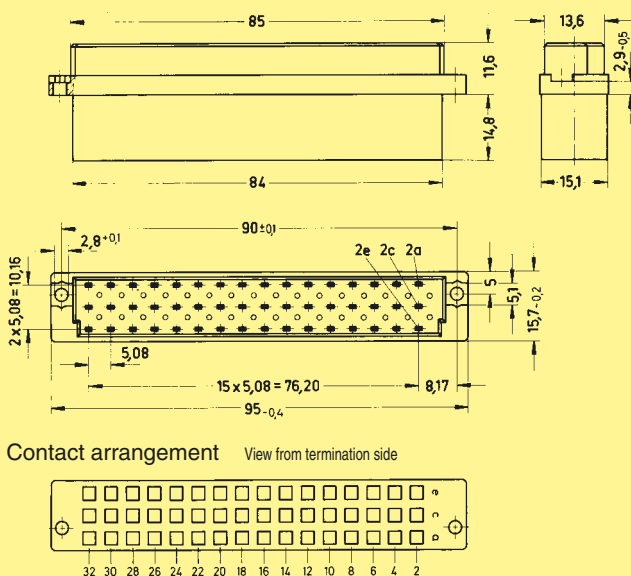

Contact arrangement View from termination side

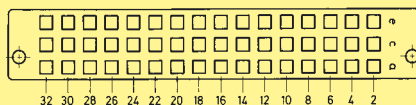

Shell housing 09 05 048 0501 see chapter 20

Identification	Identification Wire gauge	Part No.	Performance levels according to IEC 60 603-2. Explanation chapter 00
			2 1

Female crimp FC contacts

Bandoliered contacts (approx. 2,500 pieces)

1
2
3

09 06 000 6484
09 06 000 6481
09 06 000 6482

09 06 000 6474
09 06 000 6471
09 06 000 6472

Bandoliered contacts (approx. 250 pieces)

1
2
3

09 06 000 7484
09 06 000 7481
09 06 000 7482

09 06 000 7474
09 06 000 7471
09 06 000 7472

Individual contacts¹⁾

1
2
3

09 06 000 8484
09 06 000 8481
09 06 000 8482

09 06 000 8474
09 06 000 8471
09 06 000 8472

FC 1
FC 2
FC 3

1
2
3

Wire gauge mm ²	AWG	Insulation ø mm
0.09 - 0.25	28 - 24	0.7 - 1.5
0.14 - 0.56	26 - 20	0.8 - 2.0
0.5 - 1.5	20 - 16	1.6 - 2.8

Identification

Bandoliered contacts

Individual contacts

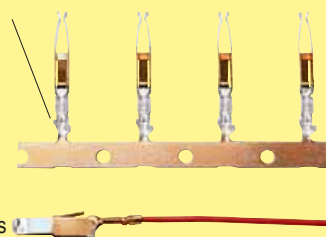

3.5 + 0.5 mm of insulation is stripped from the wires to be crimped
Insertion, removal and crimping tools see chapter 30

^{c)} Connectors with coding see page 02.42
¹⁾ Packaging unit 1,000 pieces

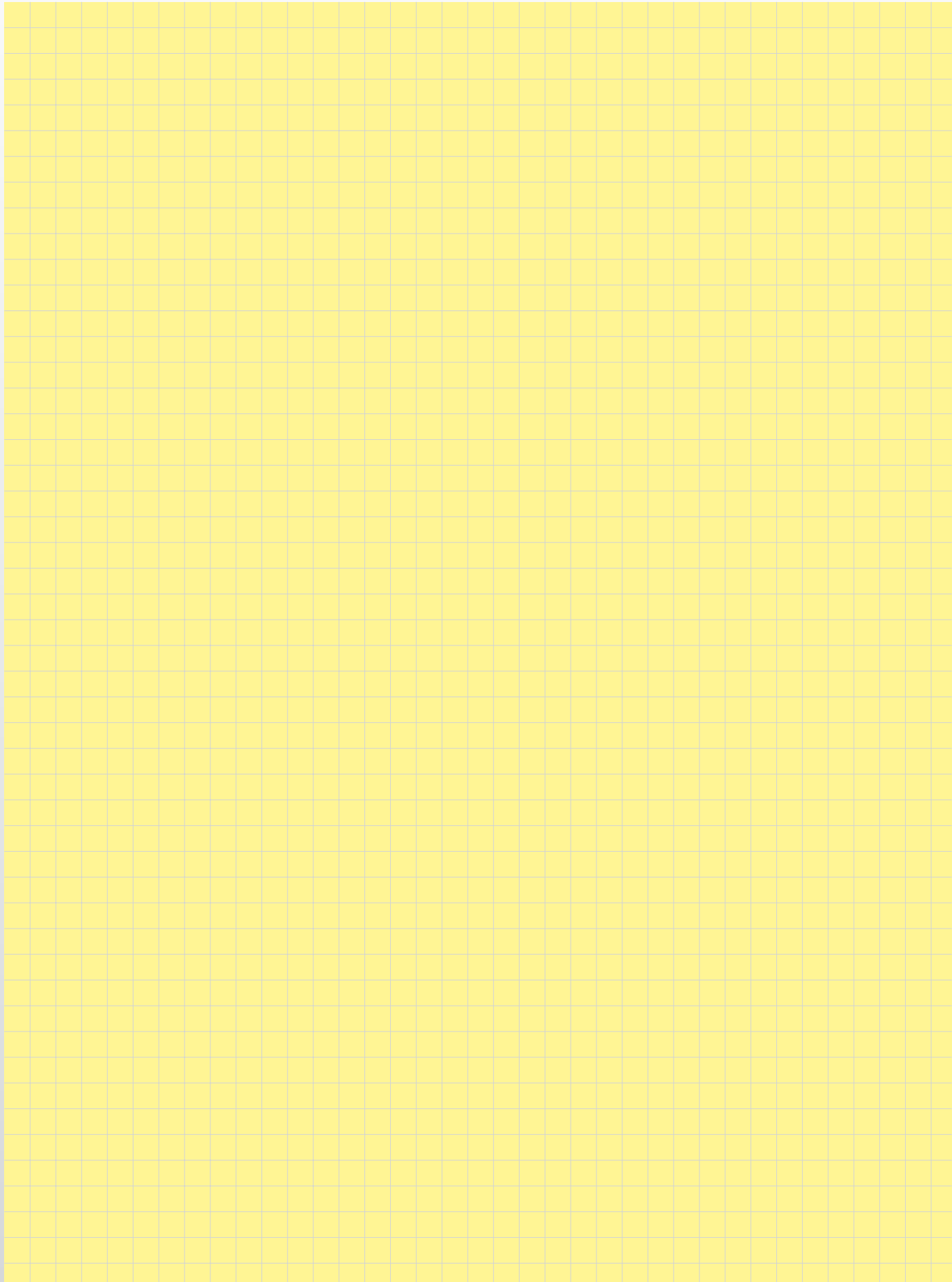

Number of contacts	16, 32, 48
Working current	6 A max. see current carrying capacity chart
Clearance	16 ways ≥ 1.6 mm 32, 48 ways ≥ 1.6 mm
Creepage	16 ways ≥ 1.6 mm 32, 48 ways ≥ 3.0 mm
Working voltage	The working voltage also depends on the clearance and creepage dimensions of the pcb itself and the associated wiring according to the safety regulations of the equipment Explanations see chapter 00
Contact resistance	≤ 20 m Ω
Insulation resistance	$\geq 10^{12}$ Ω
Termination	Crimp terminal 0.09-1.5 mm ²

Materials	
Mouldings and hoods	Thermoplastic resin, glass-fibre filled
Contacts	Copper alloy

Piggyback connectors for interfacing with female connectors with wrap posts 1 x 1 mm

The problem of interfacing systems designed for the distribution or collection of electronic signals can be overcome by the use of piggyback connectors. Designed to be mounted on the rear of DIN 41 612 type wire wrap female connectors (1 x 1 mm posts) these piggyback elements can be used to terminate input and output cables.

Distance fixing brackets are fitted to provide either a latching or screw fixing facility over the two level wire wrap plane.

The contacts used in these versions are of the female crimp type and are gold-plated to be used for 1 x 1 mm posts.

After crimping they can be easily inserted into the chambers of the connector body with the aid of an insertion tool. Insertion errors can be simply rectified with the use of a removal tool.

2 and 3 row piggyback connectors can be mounted in shell housings C and open hood G. Security is provided by either latches or screws to the distance fixing brackets.

Current carrying capacity

The current carrying capacity is limited by maximum temperature of materials for inserts and contacts including terminals. The current capacity curve is valid for continuous, non interrupted current loaded contacts of connectors when simultaneous power on all contacts is given, without exceeding the maximum temperature.

Control and test procedures according to DIN IEC 60 512

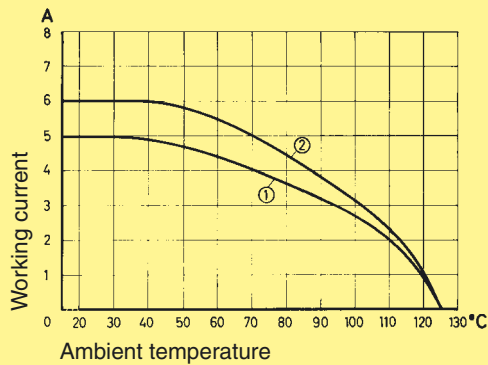

① with shell housing ② without shell housing

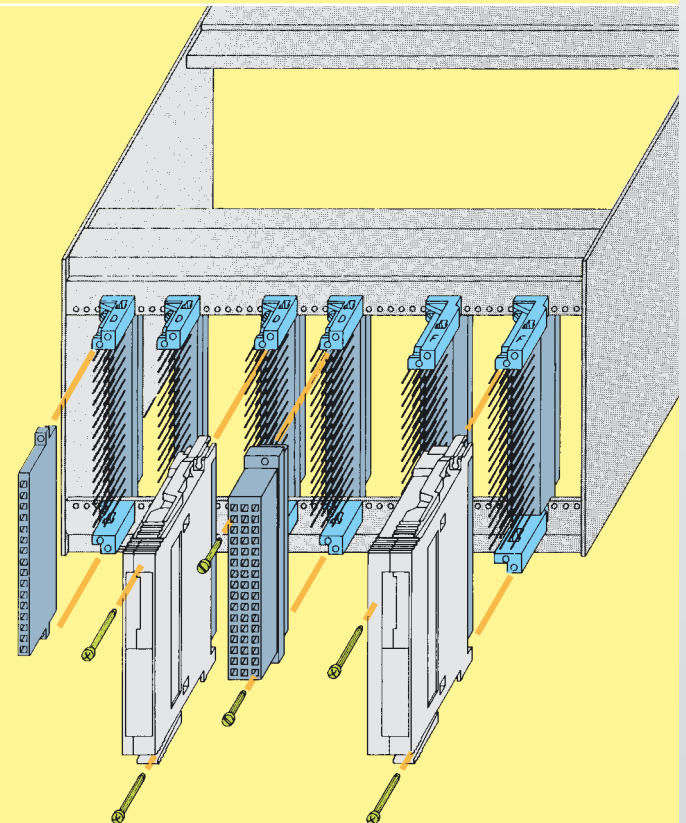

DIN Power
to 6 A

Piggyback connectors



Number of contacts

max. 48

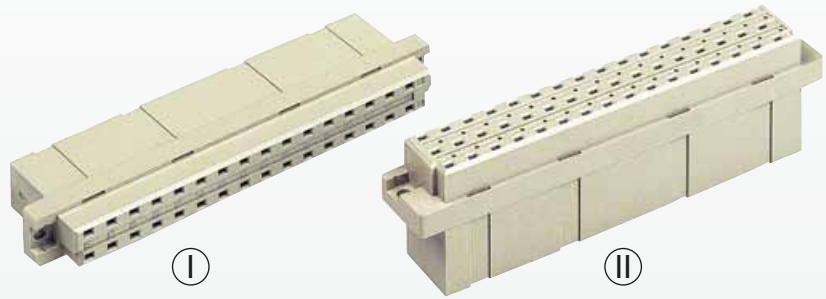

Piggyback connectors for 1 x 1 mm wrap posts

Identification	Number of contacts	Part No.	Drawing	Dimensions in mm																
Piggyback connector for crimp contacts Order contacts separately	16 32 48	09 04 016 3201 09 04 032 3215 09 05 048 3204																		
					I															
					II															
Female FC crimp contacts individual contacts ¹⁾ FC1 FC2 FC3 Bandoliered contacts (approx. 2,500 pcs.) FC1 FC2 FC3		09 06 000 6464 09 06 000 6461 09 06 000 6462 09 06 000 6454 09 06 000 6451 09 06 000 6452	<table border="1"> <thead> <tr> <th>Identification</th> <th>Wire gauge mm²</th> <th>AWG</th> <th>Insulations ø mm</th> </tr> </thead> <tbody> <tr> <td>1</td> <td>0.09-0.25</td> <td>28-24</td> <td>0.7-1.5</td> </tr> <tr> <td>2</td> <td>0.14-0.56</td> <td>26-20</td> <td>0.8-2.0</td> </tr> <tr> <td>3</td> <td>0.50-1.50</td> <td>20-16</td> <td>1.6-2.8</td> </tr> </tbody> </table>	Identification	Wire gauge mm ²	AWG	Insulations ø mm	1	0.09-0.25	28-24	0.7-1.5	2	0.14-0.56	26-20	0.8-2.0	3	0.50-1.50	20-16	1.6-2.8	<p>3.5 + 0.5 mm of insulation is stripped from the wires to be crimped. Crimping tools see chapter 30</p>
Identification	Wire gauge mm ²	AWG	Insulations ø mm																	
1	0.09-0.25	28-24	0.7-1.5																	
2	0.14-0.56	26-20	0.8-2.0																	
3	0.50-1.50	20-16	1.6-2.8																	
Mateable with 1 x 1 mm wrap posts																				
Distance fixing brackets for female connectors Type D Type E		top (pos. 2) 09 04 000 9907																		
		bottom (pos. 32) 09 04 000 9906																		
Type F		top (pos. 2) 09 06 000 9936 bottom (pos. 32) 09 06 000 9937																		

DIN Power 10 6 A

¹⁾ Packaging unit 1,000 pieces

Identification

Drawing

Dimensions in mm

Mounting examples
of piggyback
connectors

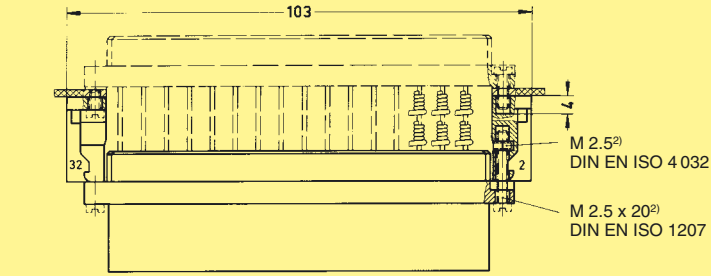

without housings

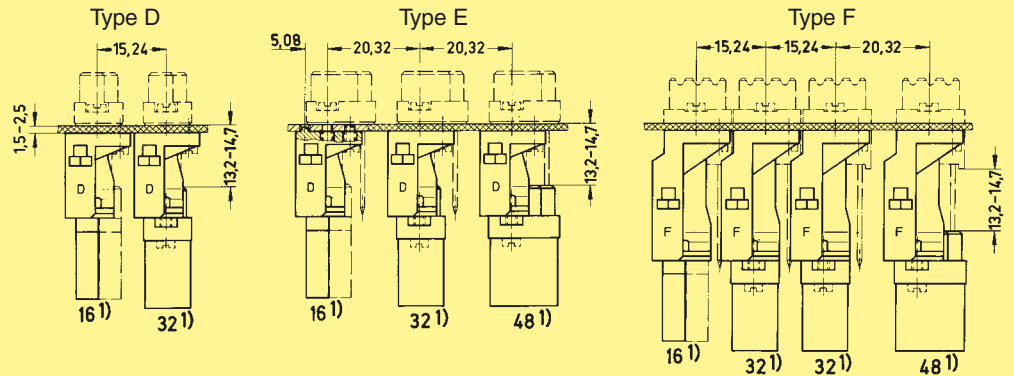

with housings

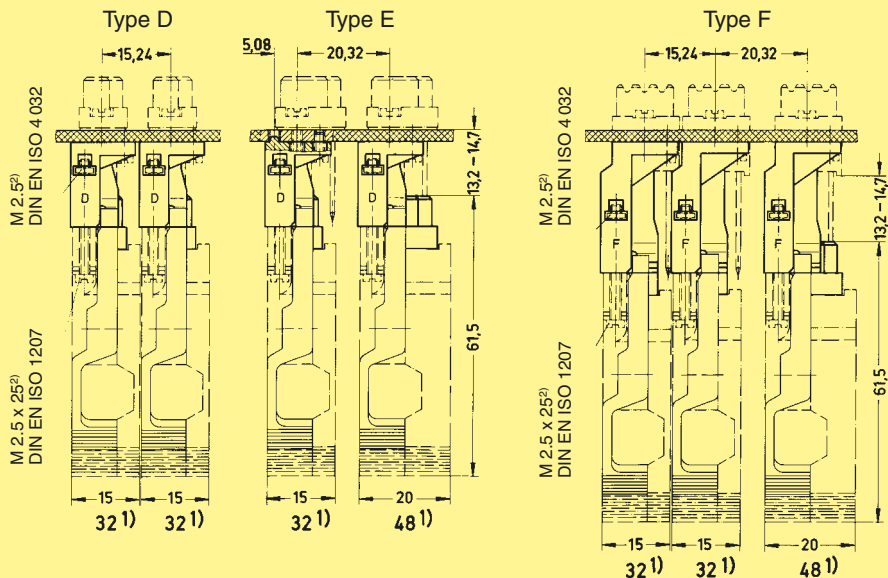
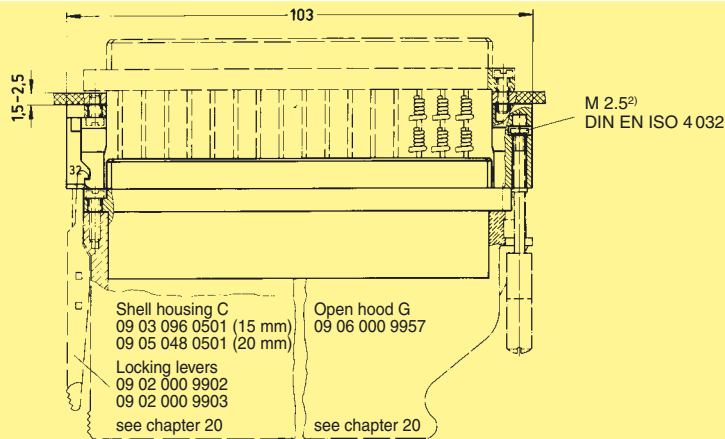

DIN Power
to 6 A

¹⁾ Number of contacts piggyback connector
²⁾ Doesn't belong to the scope of supply

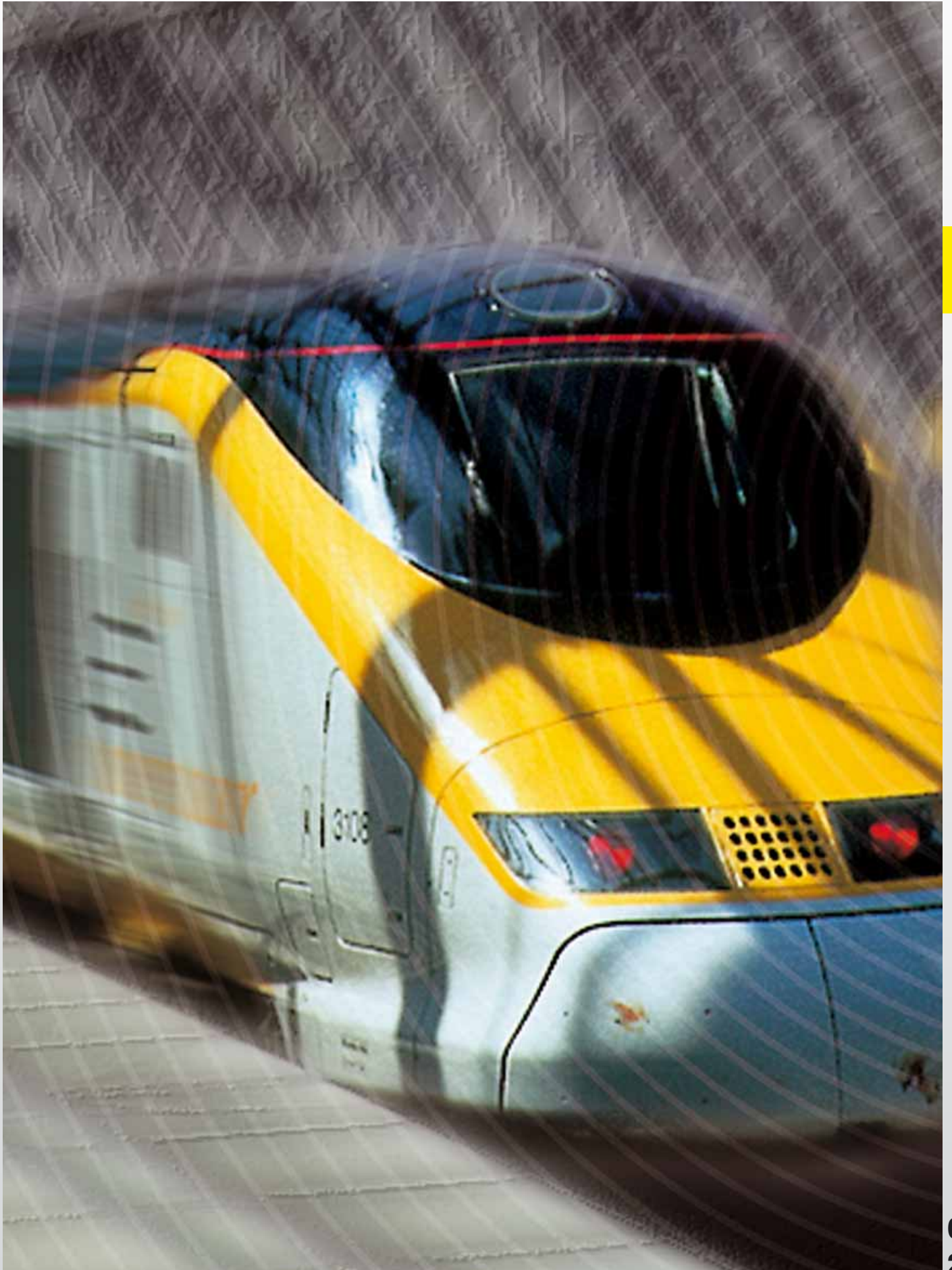

DIN Power
10 6 A

Number of contacts	
Type F	48, 32
Type FM	45
Type 2F	max. 24
Type F9	max. 9
Contact spacing (mm)	
	5.08
Working current	
	6 A max. see current carrying capacity chart
Clearance	
	≥ 1.6 mm
Creepage	
	≥ 3.0 mm
Working voltage	
The working voltage also depends on the clearance and creepage dimensions on the pcb itself and the associated wiring	according to the safety regulations of the equipment Explanations see chapter 00
Test voltage $U_{r.m.s.}$	
	1.55 kV (contact-contact) 2.5 kV (contact-ground)
Contact resistance	
	≤ 15 mΩ for wire wrap and solder connections ≤ 20 mΩ including crimp connections
Insulation resistance	
	≥ 10 ¹² Ω
Temperature range	
	- 55 °C ... + 125 °C The higher temperature limit includes the local ambient and heating effects of the contacts under load
Electrical termination	
Male connector	Solder pins for pcb connections Ø 1 ± 0.1 mm according to IEC 60 326-3 Wrap posts 1 x 1 mm diagonal 1.34-1.45 mm Crimp terminal 0.09-1.5 mm ²
Female connector	Wrap posts 1 x 1 mm diagonal 1.34-1.45 mm Solder pins for pcb connections Ø 1 ± 0.1 mm according to IEC 60 326-3 Angled solder pins 1 x 1 mm for pcb connections Ø 1.6 ± 0.1 mm Solder lugs Crimp terminal 0.09-1.5 mm ²
Distributor	Crimp terminal 0.09-1.5 mm ²
Insertion and withdrawal force	
	48 way ≤ 75 N 45 way ≤ 70 N 32 way ≤ 50 N 24 way ≤ 37 N
Materials	
Mouldings	Thermoplastic resin, glass-fibre filled, UL 94-V0
Contacts	Copper alloy
Contact surface	
Contact zone	Selectively plated according to performance level ¹⁾

¹⁾ Explanation of performance levels see chapter 00

Mating conditions see chapter 00
Coding systems see pages 02.41 and 02.42
Mounting clips see chapter 00

Current carrying capacity

The current carrying capacity is limited by maximum temperature of materials for inserts and contacts including terminals. The current capacity curve is valid for continuous, non interrupted current loaded contacts of connectors when simultaneous power on all contacts is given, without exceeding the maximum temperature.

Control and test procedures according to DIN IEC 60 512

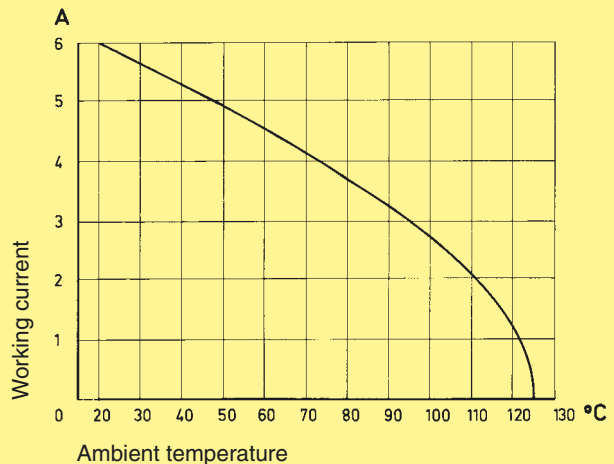

Fitting the crimp contacts

After crimping the wires onto the contacts with the help of a crimping tool or an automatic crimping machine the contacts should be correctly oriented and inserted into the cavities of the connector moulding in the required configuration. They snap into position and are firmly held in place. A light pull on the wire assures the correct tensile strength of the contact. When using stranded wires with a gauge below 0.37 mm² an insertion tool is necessary.

Removing the crimp contacts

The removal tool is inserted into a slot on the side of the respective crimp cavity. This action compresses the contact retaining spring therefore the contact can then be easily withdrawn using a light pull on the wire. This action will cause no damage to the contact/wire which can be repositioned/refitted as necessary. The drawing demonstrates the crimp removal procedure (max. 5x).

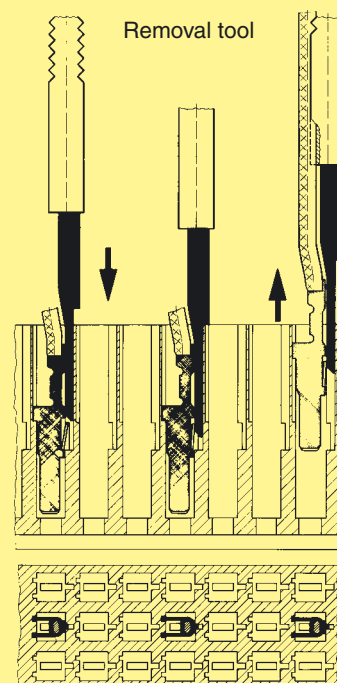

Number of contacts

48, 32

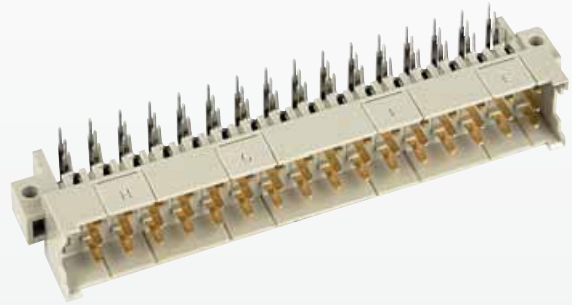

Male connectors

Identification	Number of contacts	Contact arrangement	Part No.	Performance levels according to IEC 60 603-2. Explanation chapter 00		
				3	2	1
Male connector with angled solder pins ¹⁾	48		09 06 148 7901	09 06 148 6901 09 06 348 6901 ^{b)}	09 06 148 2901	
	32		09 06 132 7901	09 06 132 6901	09 06 132 2901	
	32		09 06 132 7931	09 06 132 6931 09 06 332 6931 ^{b)}	09 06 132 2931	
	47 + 1		09 06 148 7921	09 06 148 6921	09 06 148 2921	
	31 + 1		09 06 132 7921	09 06 132 6921	09 06 132 2921	
	2 leading contacts (positions b 2 + b 32)	46 + 2			09 06 148 6925	09 06 148 2925

DIN Power to 6 A

Dimensions

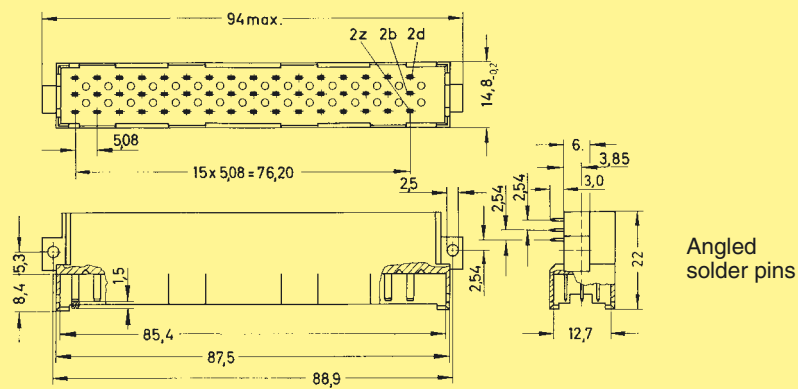

Board drillings

Mounting side

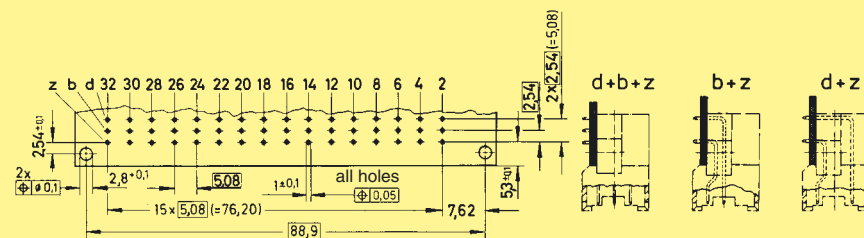

Dimensions in mm

¹⁾ With shroud coding, see also page 02.41

^{b)} Connectors with snap-in clips see chapter 00

Number of contacts

48, 32

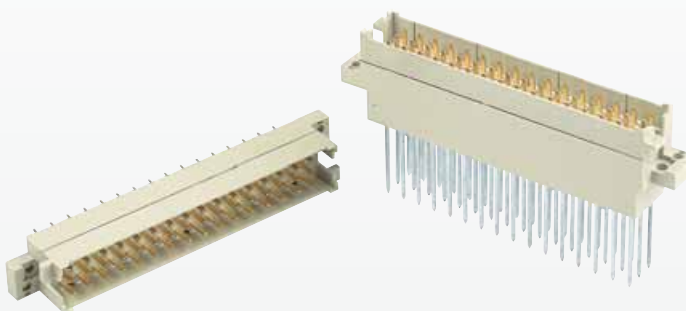

Interface connectors I

DIN Power
to 6 A

Identification	Number of contacts	Contact arrangement	Part No.	Drawing	Dimensions in mm
Interface connector I with solder pins ¹⁾ 0.6 x 0.6 mm	48		09 06 048 2905		
	32		09 06 032 2905		
	32		09 06 032 2941		
Board drillings Mounting side					
Interface connector I with wrap posts ¹⁾ 1 x 1 mm	without nut		09 06 048 2903		
	with nut		09 06 048 2963		
	without nut		09 06 032 2903		
	with nut		09 06 032 2963		
Panel cut out					

* Acc. to IEC 60 603-2, performance level 2 on request
¹⁾ With shroud coding, see also page 02.41

Number of contacts

48

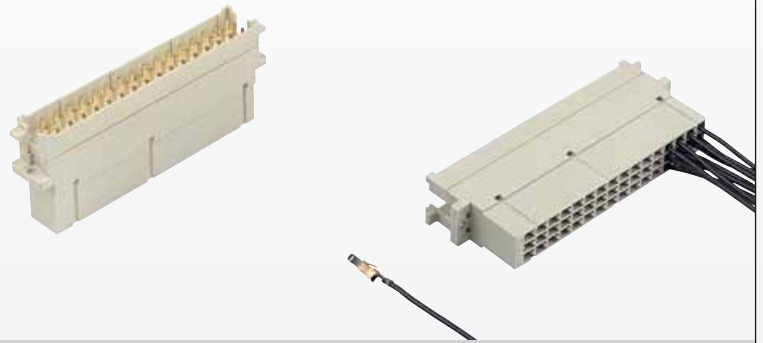

Interface connector I

Identification	Number of contacts	Part No.	Drawing	Dimensions in mm
----------------	--------------------	----------	---------	------------------

Interface connector I utilising female crimp contacts¹⁾

Order crimp contacts separately see page 02.29

48

Performance level 1 acc. to IEC 60 603-2

09 06 048 2906

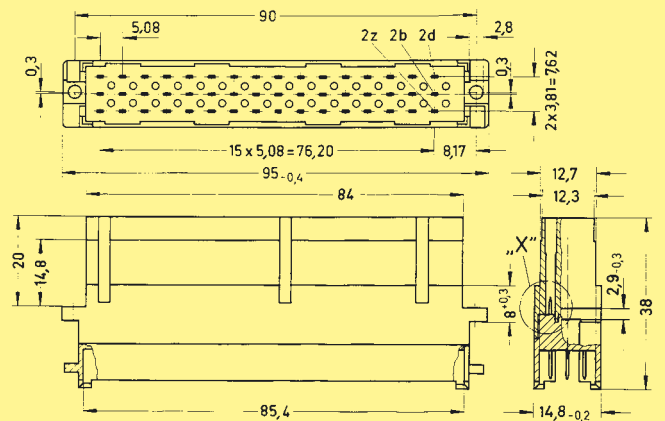

Contact arrangement View from termination side

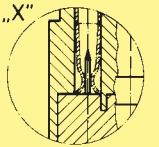
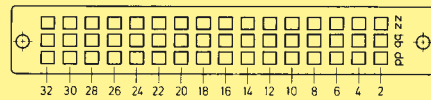

Shell housing see chapter 20

Panel cut out

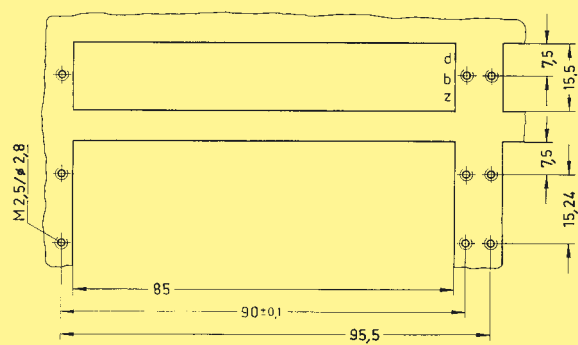

Mounted in shell housing B

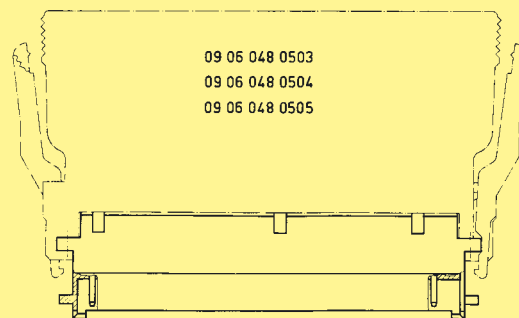

DIN Power to 6 A

¹⁾ With shroud coding, see also page 02.41

Number of contacts

48

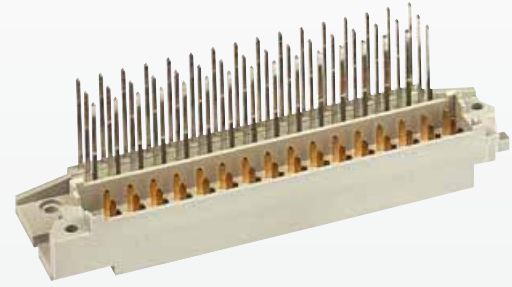

Interface connector U

DIN Power
to 6 A

Identification	Number of contacts	Part No.	Drawing	Dimensions in mm
Interface connector U with wrap posts 1 x 1 mm	48	Performance level 1 acc. to IEC 60 603-2 09 06 048 2981	<p>Technical drawing showing contact arrangement and termination side view. Dimensions include 94, 90, 817, 817, 0.3, 0.3, 94, 90, 817, 817, 0.3, 0.3.</p>	<p>Technical drawing showing mounting example with dimensions. Dimensions include 90, 1723, 1016, 817, 5.63, 5.08, 14.69, 0.3, 5.08, M 3 x 8 DIN EN ISO 1207, M 2.5 x 6 DIN EN ISO 1207, 2.4, A-B.</p>
Mounting example				

Number of contacts

max. 48

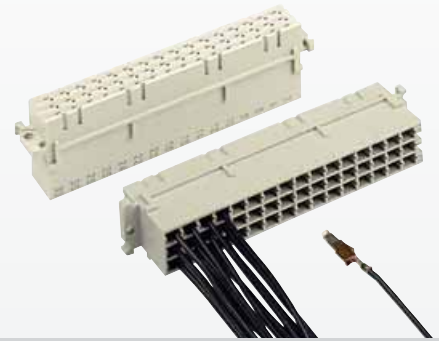

Female connectors

Identification	Number of contacts	Part No.	Drawing	Dimensions in mm
<p>Female connector for crimp contacts¹⁾ Order contacts separately</p>	48	09 06 248 3201	<p>84,9 10 8,4 14 32 30 28 26 24 22 20 18 16 14 12 10 8 6 4 2 12,4 2,9_{+0,3} 8 9,6 12,7 84,5 5,08 15 x 5,08 = 76,20 2d 2b 2z 8,17 0,3 2 x 3,81 = 7,62 14,8_{-0,2} 2,8 90 94_{-0,2}</p> <p>Contact arrangement View from termination side</p> <p>Shell housing see chapter 20</p>	

DIN Power 10 6 A

Identification	Identification Wire gauge	Part No.	Performance levels according to IEC 60 603-2. Explanation chapter 00
			2 1
Female crimp FC contacts			
Bandoliered contacts (approx. 2,500 pieces)	1	09 06 000 6484	09 06 000 6474
	2	09 06 000 6481	09 06 000 6471
	3	09 06 000 6482	09 06 000 6472
Bandoliered contacts (approx. 250 pieces)	1	09 06 000 7484	09 06 000 7474
	2	09 06 000 7481	09 06 000 7471
	3	09 06 000 7482	09 06 000 7472
Individual contacts ²⁾	1	09 06 000 8484	09 06 000 8474
	2	09 06 000 8481	09 06 000 8471
	3	09 06 000 8482	09 06 000 8472

	Wire gauge mm ²	AWG	Insulation ø mm	Identification
FC 1	0.09 - 0.25	28 - 24	0.7 - 1.5	<p>Bandoliered contacts</p> <p>Individual contacts</p>
FC 2	0.14 - 0.56	26 - 20	0.8 - 2.0	
FC 3	0.5 - 1.5	20 - 16	1.6 - 2.8	

3.5 + 0.5 mm of insulation is stripped from the wires to be crimped
Insertion, removal and crimping tools see chapter 30

¹⁾ With shroud coding, see also page 02.41

²⁾ Packaging unit 1,000 pieces

Number of contacts

48, 32



Female connectors

DIN Power
to 6 A

Identification	Number of contacts	Contact arrangement	Part No. Performance levels according to IEC 60 603-2. Explanation chapter 00		
			3	2	1
Female connector with solder pins 3.7 mm ¹⁾	48		09 06 248 7848	09 06 248 6848	09 06 248 2848
	32		09 06 232 7848	09 06 232 6848	09 06 232 2848
	32		09 06 232 7858	09 06 232 6858	09 06 232 2858
Female connector with solder pins 4.5 mm ¹⁾	48		09 06 248 7835	09 06 248 6835	09 06 248 2835
	32		09 06 232 7835	09 06 232 6835	09 06 232 2835
	32		09 06 232 7845	09 06 232 6845	09 06 232 2845

Dimensions

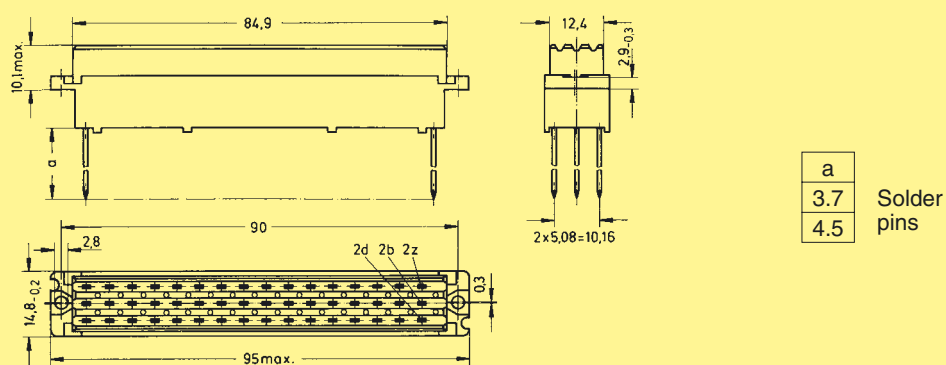

Board drillings

Mounting side

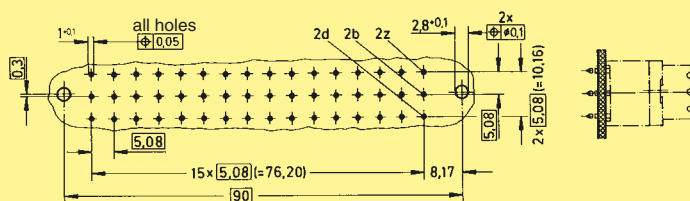

Dimensions in mm

¹⁾ With shroud coding, see also page 02.41

Number of contacts

48, 32

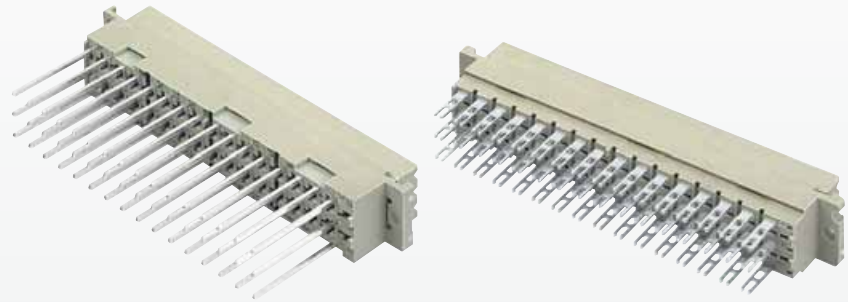

Female connectors

Identification	Number of contacts	Contact arrangement	Performance levels according to IEC 60 603-2. Explanation chapter 00		
			Part No. 3	2	1
Female connector with wrap posts 22 mm	48		09 06 248 7821	09 06 248 6821	09 06 248 2821
	32		09 06 232 7821	09 06 232 6821	09 06 232 2821
	32		09 06 232 7831	09 06 232 6831	09 06 232 2831
Female connector with solder lugs open solder lug 	48		09 06 248 7823	09 06 248 6823	09 06 248 2823
	32		09 06 232 7823	09 06 232 6823	09 06 232 2823
	32		09 06 232 7843	09 06 232 6843	09 06 232 2843

DIN Power 10 6 A

Dimensions

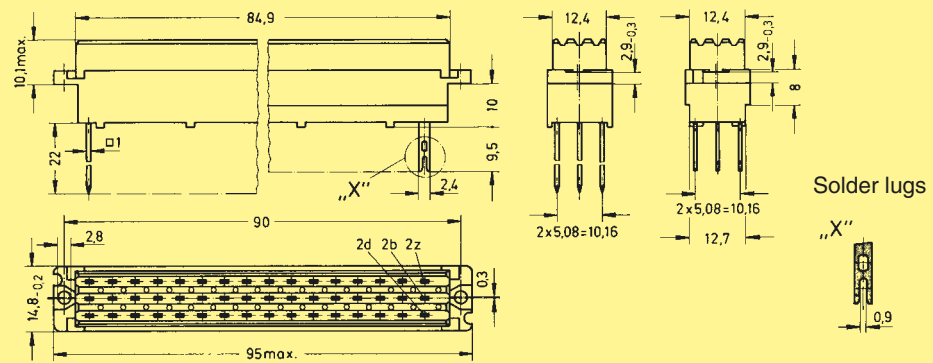

Panel cut out

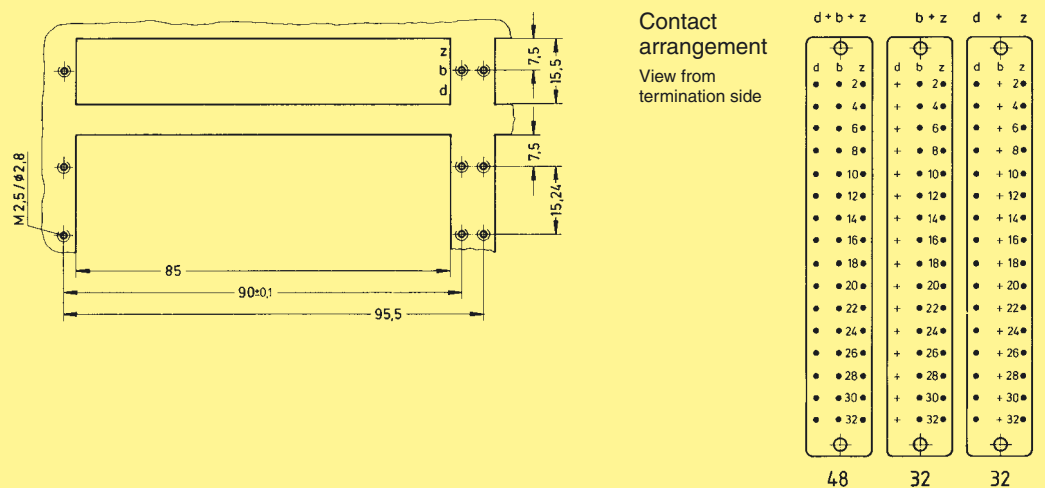

Dimensions in mm

Number of contacts

48, 32

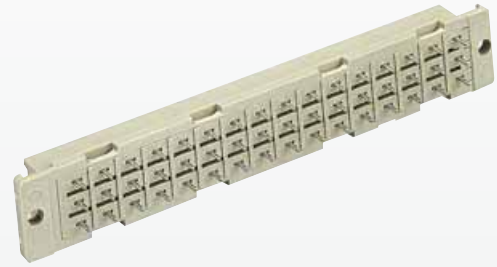

Female connectors

DIN Power
to 6 A

Identification	Number of contacts	Contact arrangement	Part No. Performance levels according to IEC 60 603-2. Explanation chapter 00		
			3	2	1
Female connector "low profile" with solder pins 3.2 mm	48		09 06 248 7833	09 06 248 6833	09 06 248 2833
	32		09 06 232 7833	09 06 232 6833	09 06 232 2833
	32		09 06 232 7893	09 06 232 6893	09 06 232 2893
Female connector "low profile" with solder pins 4.5 mm	48		09 06 248 7834	09 06 248 6834	09 06 248 2834
	32		09 06 232 7834	09 06 232 6834	09 06 232 2834
	32		09 06 232 7894	09 06 232 6894	09 06 232 2894

Female connector with press-in pins

Part Nos. and variants see chapter 04

Dimensions

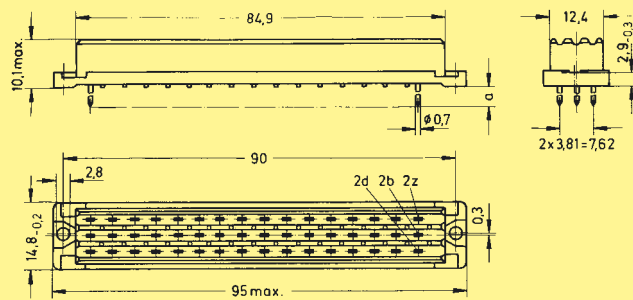

a	Solder pins
3.2	
4.5	

Board drillings

Mounting side

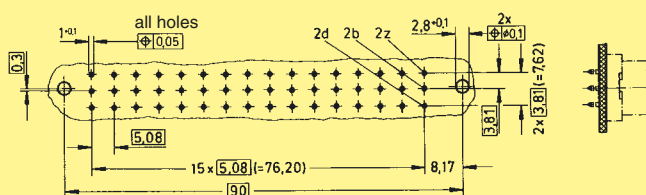

Dimensions in mm

Number of contacts

48, 32

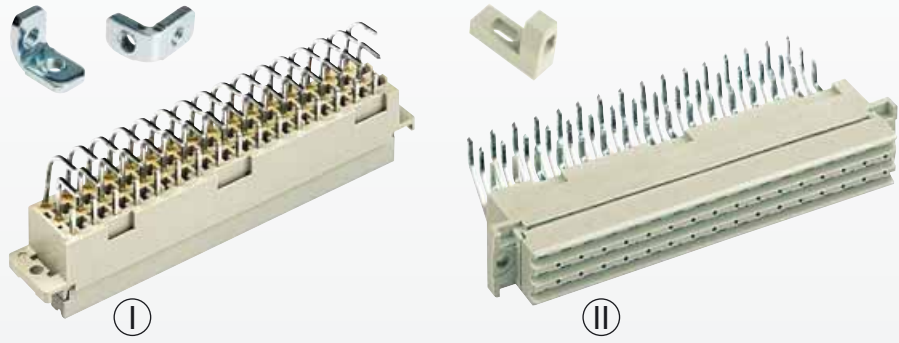

Female connectors

Identification	Number of contacts	Contact arrangement	Part No.	Performance levels according to IEC 60 603-2. Explanation chapter 00		
				3	2	1
Female connector with angled solder pins 1 x 1 mm	48		09 06 248 7826	09 06 248 6826		
	32		09 06 232 7826	09 06 232 6826		
	48		09 06 248 7836	09 06 248 6836		
	32		09 06 232 7846	09 06 232 6846		
	32		09 06 232 7836	09 06 232 6836		
	Dimensions					
Fixing bracket		Metal	09 06 000 9912 ¹⁾	for version		
¹⁾ Order 2 pieces for one connector		Plastic	09 06 000 9975 ¹⁾	for version		
Board drillings Mounting side						

DIN Power 10 6 A

Number of contacts

16, 64



Universal adaptors

DIN Power
10 6 A

Identification	Number of contacts	Part No.	Drawing	Dimensions in mm
Universal adaptor utilising crimp contacts crimp contacts see page 02.29	4 x 4	09 06 016 3301		
	16 x 1	09 06 016 3302		
	16 x 4	09 06 064 3302		
Panel cut out				

Number of contacts

max. 9

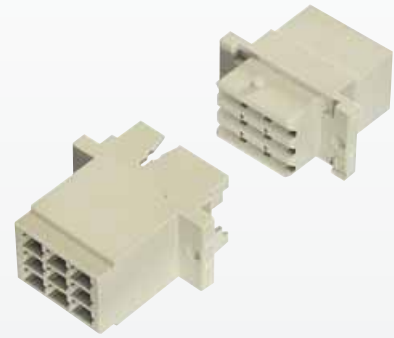

Female and male connectors

Identification	Number of contacts	Part No.	Drawing	Dimensions in mm
----------------	--------------------	----------	---------	------------------

Female connector for crimp contacts
Order contacts separately

9

09 06 209 3201

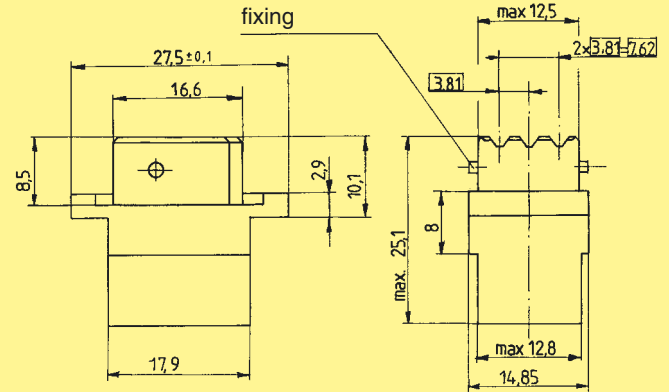

Female crimp contacts

see page 02.29

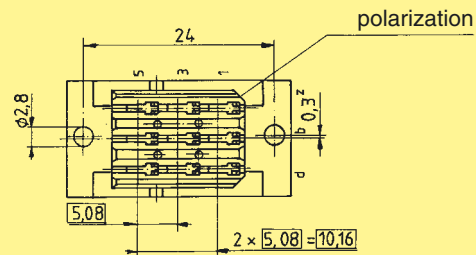

Male connector for crimp contacts
Order contacts separately

9

09 06 109 3401

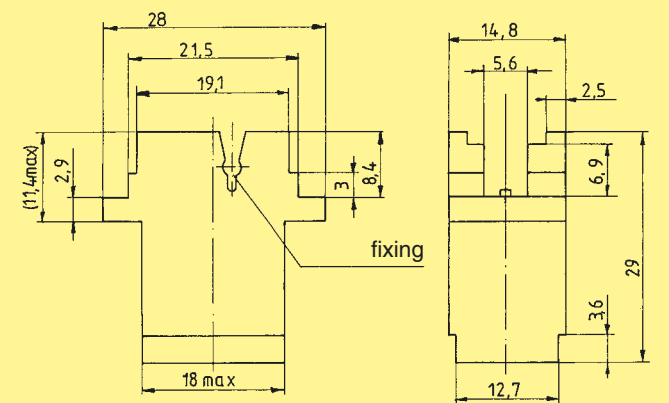

Male crimp contacts

see page 02.38

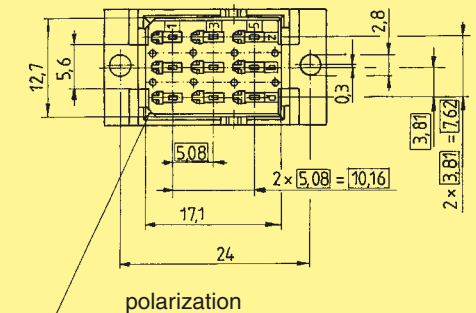

DIN Power 10 6 A

Number of contacts

45

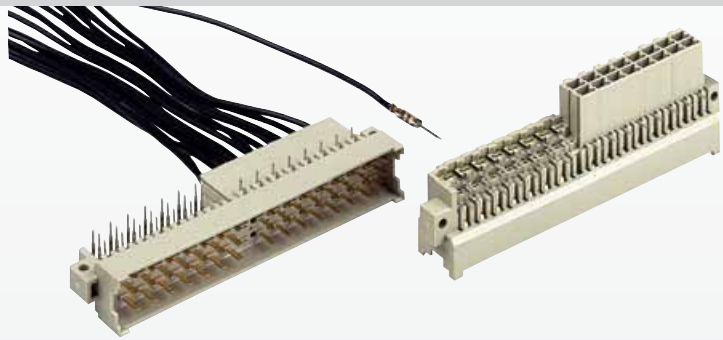

Male connectors

DIN Power
to 6 A

Identification	Number of contacts	Part No.	Drawing	Dimensions in mm
----------------	--------------------	----------	---------	------------------

Male connector	45	09 06 145 2971	
29 angled solder pins			
16 cavities for male crimp contacts			

crimp contacts see page 02.38 Board drillings Mounting side			
---	--	--	--

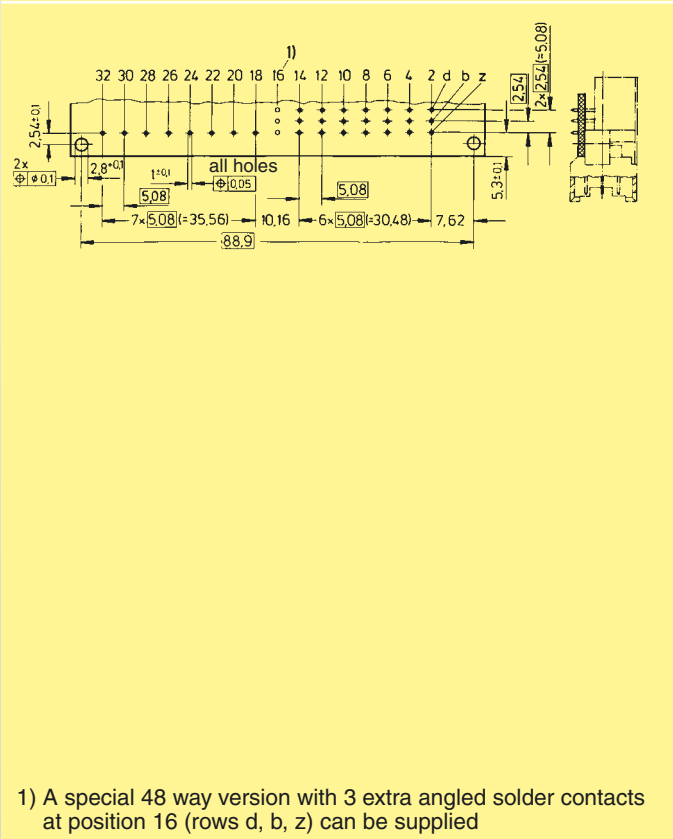
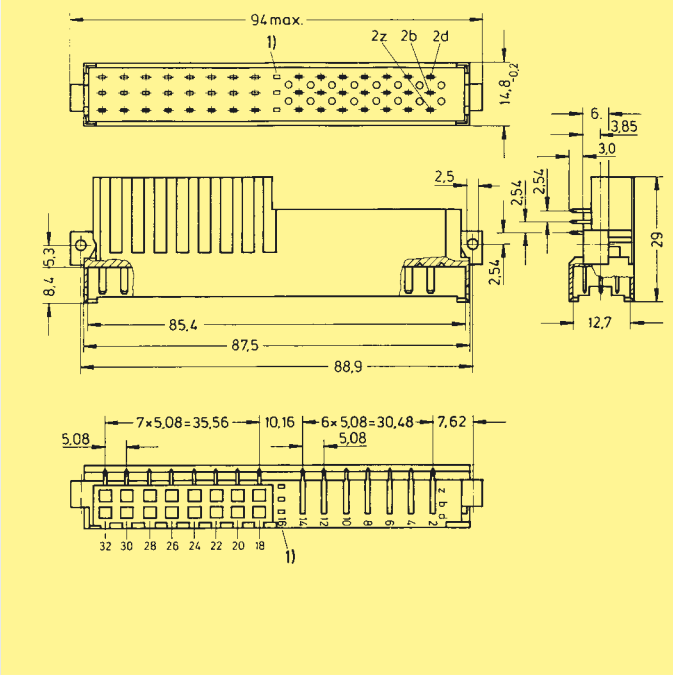

1) A special 48 way version with 3 extra angled solder contacts at position 16 (rows d, b, z) can be supplied

Number of contacts

45

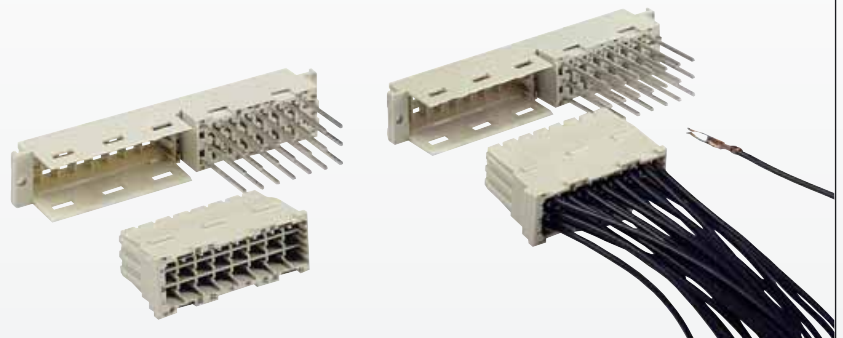

Female connectors

Identification	Number of contacts	Part No.	Drawing	Dimensions in mm
----------------	--------------------	----------	---------	------------------

Female connector

Female moulding

with 21 wrap posts
22 mm

with 21 solder pins
4.5 mm

45

Performance level 1
acc. to IEC 60 603-2

09 06 045 2872

09 06 045 2875

Crimp moulding

for 24 female
crimp contacts

09 06 024 3202

crimp contacts
see page 02.29

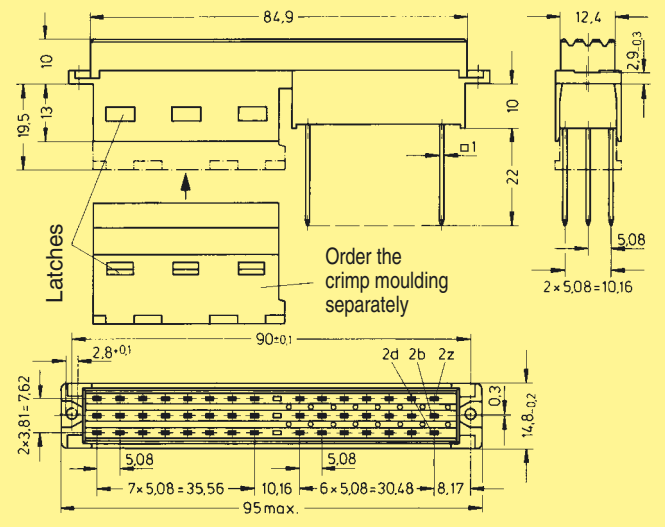

Contact arrangement View from termination side

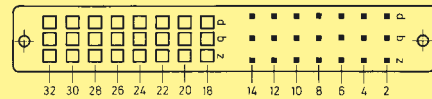

Panel cut out

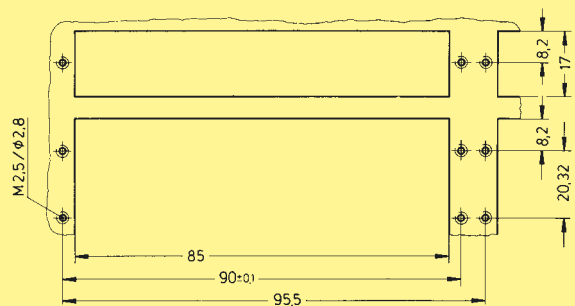

Removal tool
for the crimp
moulding

09 99 000 0172

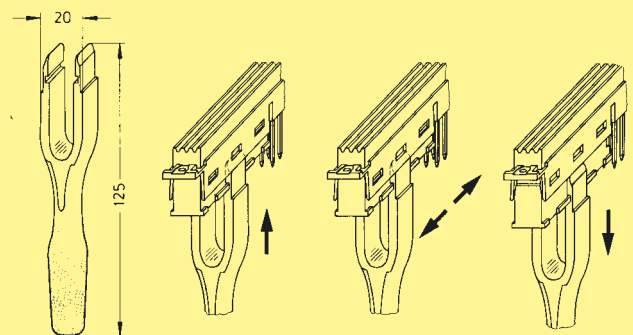

The crimp moulding can be extracted with the help of the removal tool.

Number of contacts

max. 24

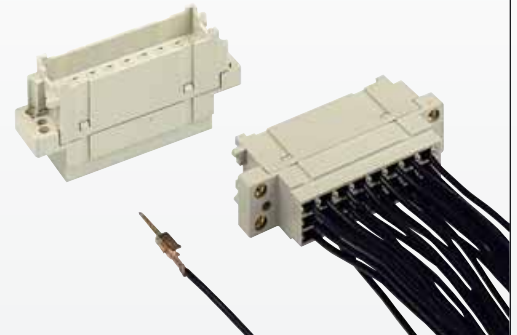

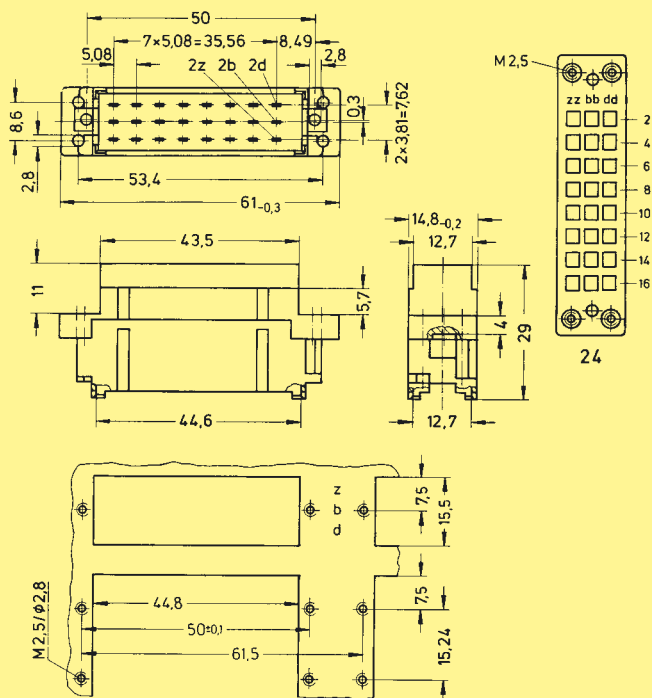

Interface connector I

DIN Power
10 6 A

Identification	Number of contacts	Part No.	Drawing	Dimensions in mm
Interface connector I for male crimp contacts Order contacts separately	24	09 26 024 3411		

Identification	Identification Wire gauge	Part No.	Performance levels according to IEC 60 603-2. Explanation chapter 00
			2 1
Male crimp FC contacts			
Bandoliered contacts (approx. 2,500 pieces)	1 2 3	09 06 000 9564 09 06 000 9561 09 06 000 9562	09 06 000 9544 09 06 000 9541 09 06 000 9542
Individual contacts ¹⁾	1 2 3	09 06 000 9574 09 06 000 9571 09 06 000 9572	09 06 000 9554 09 06 000 9551 09 06 000 9552

	FC 1	FC 2	FC 3	Wire gauge mm ²	AWG	Insulation ø mm	Identification
				0.09 - 0.25	28 - 24	0.7 - 1.5	
				0.14 - 0.56	26 - 20	0.8 - 2.0	
				0.5 - 1.5	20 - 16	1.6 - 2.8	

3.5 + 0.5 mm of insulation is stripped from the wires to be crimped
Insertion, removal and crimping tools see chapter 30

¹⁾ Packaging unit 1,000 pieces

Number of contacts



max. 24



Female connectors

DIN Power
10 6 A

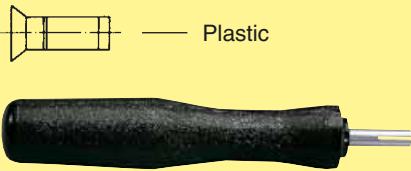
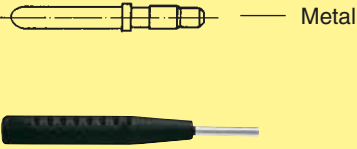
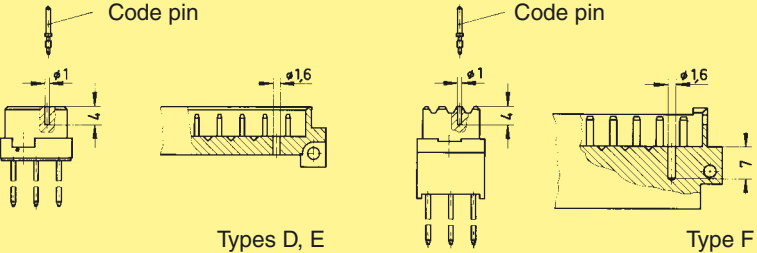
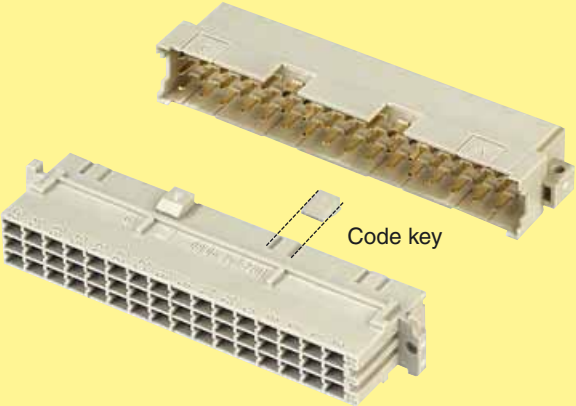
Identification	Number of contacts	Part No.	Drawing	Dimensions in mm
<p>Female connector for crimp contacts</p> <p>Order contacts separately see page 02.29</p>	24	09 26 024 3201		
<p>Shell housing A with integrated fixing screws</p> <p>Supplied with: Shell 2x Locking screw 2x Screw M3x10 2x Nut M3 2x Screw BZ 2.9x9.5 2x Cable clamp 1x Tension relief 1x</p> <p>Open hood</p> <p>Supplied with: Open hood 1x Locking screw 2x Screw BZ 2.2x9.5 2x Cable tie 1x</p>		09 26 024 0401		09 26 000 9901

Identification	Part No.	Drawing	Dimensions in mm
<p>Coding system <u>with</u> contact loss</p>	<p>Code pin for types D, E, F, FM, 2F 09 04 000 9908</p> <p>Removal tool for male contacts 09 99 000 0038</p>	<p>To avoid accidental and incorrect mating of adjacent connectors a coding system is required. The coding is achieved by means of a code pin which is inserted into the selected chamber of the female connector (the contact cavity must be filled with a female contact!). The opposite male contact must be removed with the help of the specially designed tool.</p> 	
<p>Coding system <u>without</u> contact loss</p> <p>with code pin</p>	<p>Code pin 09 06 000 9950</p> <p>Insertion tool 09 99 000 0103</p>	<p>With the aid of the marked indents between the contact rows of the male connector a hole has to be drilled at the desired position (also see drawing). The code pin can then be inserted into the corresponding cavity of the female connector by means of the insertion tool. This coding system is available only for the types D, E, F and interface connectors I</p>  <p>Mounting example</p> 	
<p>shroud coding</p> <p>Type F</p>	<p>Code key 09 06 001 9919</p>	<p>Insert the code key into one of the keyways of the female connector as shown in the drawing. Break out the corresponding area of the male shroud.</p> <p>Connectors coded this way can only be applied in a minimum rack spacing of 20.32 mm.</p> 	
<p>Tool for breaking out the coding area of the male shroud</p>	<p>09 99 000 0242</p>		

DIN Power
10 6 A

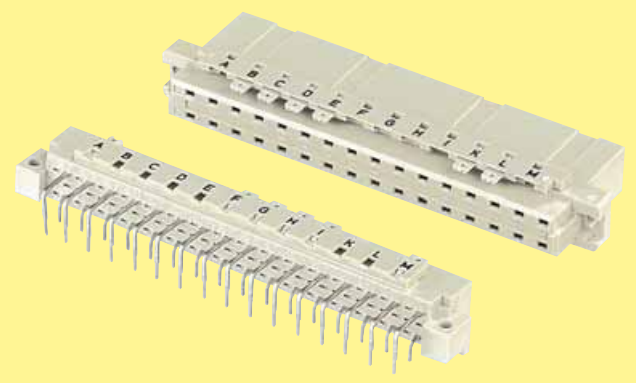
Identification	Part No.	Drawing	Dimensions in mm
<p>Coding system <u>without</u> contact loss</p>	<p>Male and female connectors</p> <p>Types B, C, D and E</p> <p>see product pages or on request</p>	<p>To avoid accidental and incorrect mating of adjacent connectors a coding system is required. This coding system is an integral part of both male and female connectors. A comb with 12 coding pins, which is supplied under a single part number, allows over 900 coding variations. The pins are to be locked into the male and female connectors.</p> <p>The connectors with the integrated coding facility are supplied for types B, C, D and E and are available for all variants.</p> <p>Please contact us.</p> 	
<p>Coding pins</p> <p>Mounting example</p>	<p>12 pins on a comb</p> <p>09 02 000 9928</p>	